

Autogard Torque Limiter 820 Series





Autogard Torque Limiter 820 Series

For more than 80 years, Autogard® products have led the industry in overload protection with high-quality products, design innovation and production. Autogard products are manufactured to meet ISO 9001 using the latest machine tools and high-quality materials.

Acting like a mechanical “fuse” to protect the weakest member of the drive train, the most effective location for Autogard Torque Limiters is as close as possible to the component being protected. The 820 Series has been designed using a modular principle to meet the emerging need for a high-torque, high- and low-speed torque limiter. The trip torque setting can be set to virtually any value depending upon the radius at which the modules are located, the number of modules used and module load setting.

Disengagement on overload

A hardened seat ‘A’ is built into one half of the torque limiter. The module unit is then located into the opposing flange in a way that the torque is transmitted between the plunger ‘B’ and the hardened seat. This produces an end thrust in the plunger in proportion to the applied torque. This force is resisted by a ring of segments ‘C’ trapped between a flat surface and a conical washer loaded by disc springs ‘D.’ When the axial force reaches a level greater than the reaction force through the spring mechanism, the plunger will retract forcing the segments up the plunger slope and allowing the plunger to disengage from the hardened seat. The torque limiter is now allowed to run free. The modular torque limiter may incorporate an optional limit switch plate that moves on trip and can operate a switch to stop the device.

Re-engagement

Resetting is accomplished by simply aligning the two halves, positioning the plunger over the hardened seat, and tapping the reset pin ‘G’ with a soft hammer. A remote reset version is also available. If required, the trip torque is externally adjusted and is achieved by turning the adjustment nut ‘E’ to increase or decrease the spring pressure.

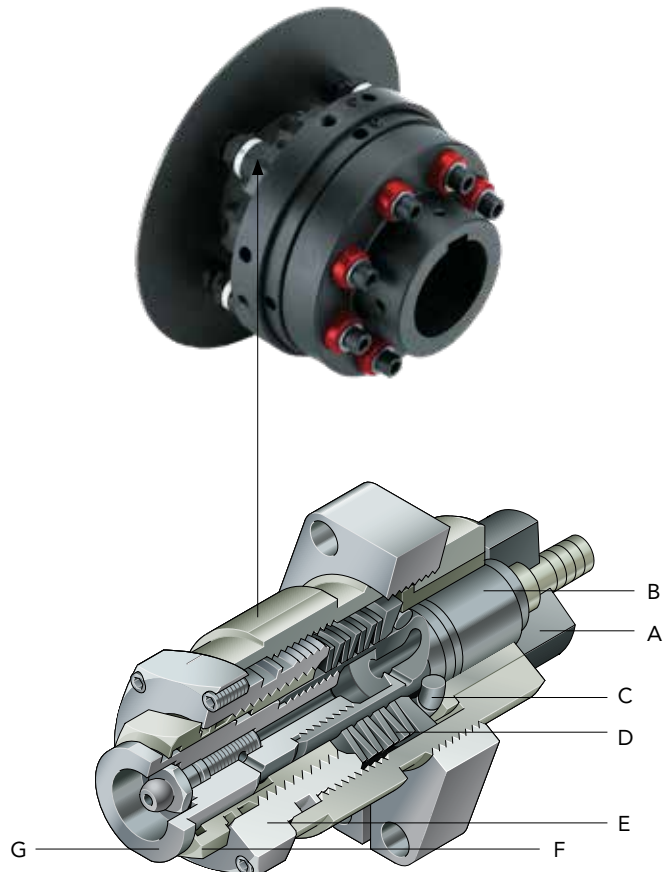

Letters above correspond to paragraphs on the left.



Features and Benefits:

- Accommodates high-torque application with high or low speeds
- Accurate and consistent torque setting ensuring reliable and repeatable torque overload protection
- Instant and complete disengagement of the driving and driven inertias ensuring optimum protection
- Trip torque can be adjusted easily without removing modules from the torque limiter
- Vernier scales are provided on each module allowing for accurate setting of the modules
- In the event of an overload, standard limit switches or proximity sensors can provide automatic motor shutdown
- Modules can be quickly and easily reset — manual or automatic resets available
- Manual disengagement allows for the unit to be disconnected for maintenance purposes
- Integral grease fitting allows for periodic lubrication of the unit without removing it from the drive line
- Wide range of mounting configurations ensures the right solution for any problem
- Drop-out center section allows the torque limiter to be removed from the drive line without moving the equipment

Selection:

Data required for torque limiter selection:

- Application details for service factors
- Kilowatt or horsepower (hp) and rpm of the driver
- Shaft details of the driving and driven equipment

(1) Calculate the nominal torque.

$$\text{Torque (Nm)} = \text{Kw} \times 9550 / \text{rpm}$$

Consideration should then be given to start torque or other special circumstances depending on the position chosen in the drive system. Choose a set torque with a suitable margin over nominal. Select the torque limiter which has a higher torque rating.

(2) Check limiting conditions:

- (a) Check hub bore capacity
- (b) Check the torque limiter dimensions such as the overall length and outside diameter

(3) Select and specify the appropriate drive medium or coupling.

All Autogard 820 Series units may be supplied from the factory at a pre-set torque and with the required drive medium assembled to the unit.

820 Series Industries

Mining
Energy
Steel
Paper

Ordering the 820 Series Torque Limiter

When ordering, please provide the following designation:

Model & Size / Type / S1 Bore / S2 bore.

Standard bore tolerance = H7 + normal fit key

Example: 820-3L / 2 / S1-100 / S2-120

Refers to a 820 Series, size 3L, Type 2 torque limiter

Bore S1 = 100mm Bore S2 = 120mm

Also specify setting torque if required.

Type 1

Type 1 Model includes a pin and bush elastic coupling.

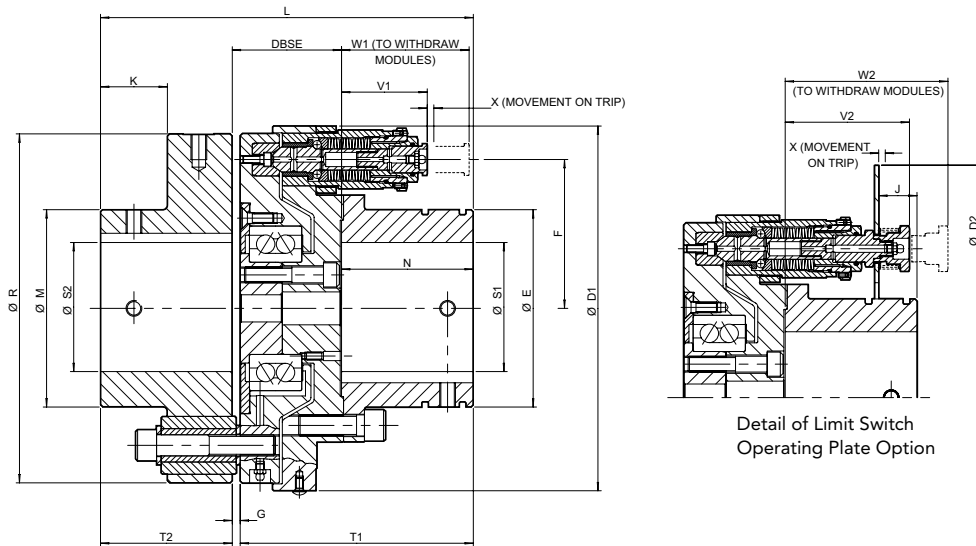

Size ⊙⊙	Modules (Size-Qty)	Torque		Coupling Torque		Max Speed rpm	Mass kg [ⓐ]	Mass Moment of Inertia MR ² [ⓑ] kgm ²	Max. Axial Misalign. mm	Max. Parallel Misalign. mm
		Min Nm	Max Nm	Nominal Nm	Peak Nm					
1L	1L-4	370	1,470	2,120	4,240	3800	33.2	0.135	3.0	0.13
1H	1H-4	735	2,940	2,120	4,240	3800	33.4	0.136	3.0	0.13
2L	2L-3	860	3,450	6,340	12,680	2400	75.8	0.543	3.0	0.13
2H	2H-3	1,725	6,900	6,340	12,680	2400	76.2	0.549	3.0	0.13
3L	2L-4	1,400	5,650	9,650	19,300	2150	124	1.27	3.5	0.13
3H	2H-4	2,825	11,300	9,650	19,300	2150	125	1.28	3.5	0.13
4L	3L-4	3,050	12,200	18,070	36,140	1800	244	3.72	3.5	0.13
4H	3H-4	6,100	24,400	18,070	36,140	1800	246	3.78	3.5	0.13
5L	4L-3	6,540	26,150	35,000	70,000	1800 [ⓐ]	472	12.6	3.5	0.13
5H	4H-3	13,075	52,300	35,000	70,000	1800 [ⓐ]	476	12.8	3.5	0.13
6	5-3	60,000	120,000	Designed to customer specification. Consult Rexnord.						

ⓐ Max angular misalignment 0.25°.

ⓑ Balancing optional.

ⓒ Consult Rexnord if limit switch plate is required at speeds above 1,400 rpm.

ⓓ Mass and inertia values calculated for units with solid hubs without limit switch plate.



Size	S1 (max) mm	S2 (max) mm	DBSE mm	D1 mm	D2 mm	E mm	F mm	G mm	J mm	K mm	L mm	M mm	N mm	R mm	T1 mm	T2 mm	V1 mm	V2 mm	W1 mm	W2 mm	X mm
1L	80	85	63.2	212	288	115	85.5	6.0	32.6	45.5	223	118.5	80.0	195	137	80.0	50.4	70.8	76.4	93.0	3.7
1H	80	85	63.2	212	288	115	85.5	6.0	22.6	45.5	223	118.5	80.0	195	137	80.0	60.4	80.8	86.4	103	3.7
2L	100	115	83.0	277	353	150	113	6.0	43.1	50.8	283	162.5	100	265	177	100	51.1	80.4	84.9	110	5.0
2H	100	115	83.0	277	353	150	113	6.0	29.1	50.8	283	162.5	100	265	177	100	65.1	94.4	98.9	124	5.0
3L	120	130	93.4	329	405	180	139	7.0	63.0	60.0	333	188.5	120	314	206	120	51.1	80.4	84.9	110	5.0
3H	120	130	93.4	329	405	180	139	7.0	49.0	60.0	333	188.5	120	314	206	120	65.1	94.4	98.9	124	5.0
4L	150	170	114.8	409	485	230	166	7.0	70.0	89.9	415	248.0	150	375	258	150	76.0	109.4	126	131	6.0
4H	150	170	114.8	409	485	230	166	7.0	46.0	89.9	415	248.0	150	375	258	150	100.0	133.4	150	155	6.0
5L	180	205	134.8	550	626	280	221	7.0	57.1	119.9	495	310.0	180	470	308	180	118.9	152.3	186	192	8.0
5H	180	205	134.8	550	626	280	221	7.0	25.1	119.9	495	310.0	180	470	308	180	150.9	184.3	218	224	8.0
6	230	230	Designed to customer specification. Please consult Rexnord.																		12.0

820 Series Type 1 Pin Coupling Selection Method

When selecting a 820 Series, Type 1, please confirm the coupling is suitable for the continuous torque, taking into account the duty in which the unit will be used.

- Determine the nominal torque: $\text{Torque (Nm)} = K_w \times 9550 / \text{rpm}$
- Select the appropriate service factor f_D as shown in Table 1.
- From Table 2 select the factor for the frequency of starts per hour (f_g).
- Determine selection torque: $\text{Selection Torque (Nm)} = \text{nominal torque} \times f_D \times f_g$
- Check to ensure that the coupling's nominal torque rating exceeds the selection torque. If not, select the next larger torque limiter that meets this criteria.

Table 1: Pin coupling service factor (f_D) for 820 Series Type 1 only.

Prime Mover (Drive input)	Driven Machinery Characteristics			
	Duration Service (Hours/Day)	Steady Load	Medium Impulsive	Highly Impulsive
Electric Air, Hydraulic Motors, Steam Turbines (Steady Input)	Intermittent 3 hrs/day max	0.90	1.00	1.50
	3-10	1.00	1.25	1.75
	Over 10	1.25	1.50	2.00
Multi-cylinder I.C. Engine (Medium Impulsive Input)	Intermittent 3 hrs/day max	1.00	1.25	1.75
	3-10	1.25	1.50	2.00
	Over 10	1.50	1.75	2.25
Single-cylinder I.C. Engine (Highly Impulsive Input)	Intermittent 3 hrs/day max	1.25	1.50	2.00
	3-10	1.50	1.75	2.25
	Over 10	1.75	2.00	2.50

Table 2: Pin coupling service Factor (f_g) for 820 Series Type 1 only.

Number of Starts per Hour	0-1	1-30	30-60	60+
Factor	1.00	1.20	1.30	1.50

Notes:

Service factors are for reference only.

For applications with excessive vibration, contact Rexnord.

Rotating equipment must be provided with suitable guarding, or injury may result.

Type 3

Type 3 Model accepts torsionally rigid disc coupling.

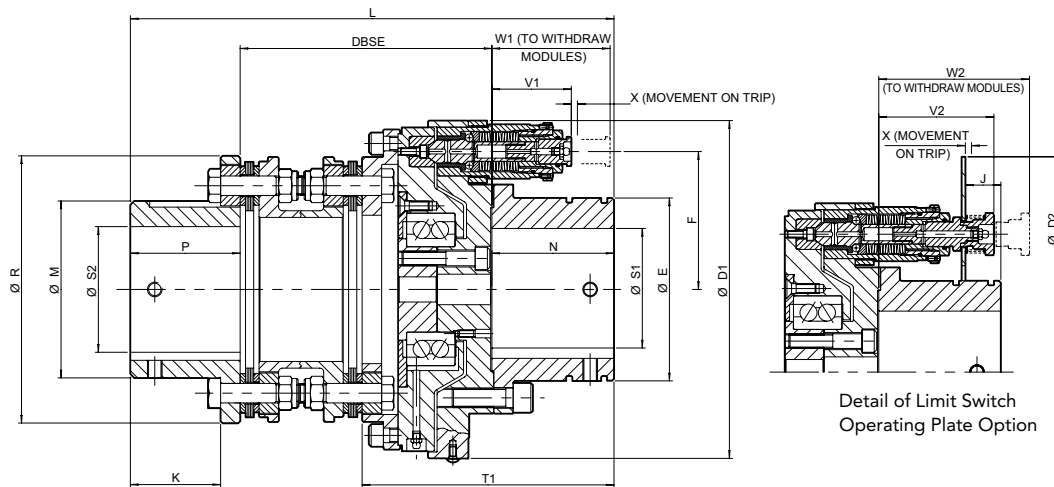

Size ①	Modules (Size-Qty)	Torque		Coupling Max Continuous Torque Nm	Max speed rpm	Mass kg ④	Mass Moment of Inertia MR ² kgm ² ③	Max. Axial Misalign. mm	Max. Parallel Misalign. mm
		Min Nm	Max Nm						
1L	1L-4	370	1,470	3,300	3800	47.4	0.214	1.79	0.77
1H	1H-4	735	2,940	3,300	3800	47.7	0.216	1.79	0.77
2L	2L-3	860	3,450	7,000	2400	91.6	0.677	2.29	0.90
2H	2H-3	1,725	6,900	7,000	2400	92.0	0.683	2.29	0.90
3L	2L-4	1,400	5,650	13,000	2150	170	1.87	2.89	1.09
3H	2H-4	2,825	11,300	13,000	2150	171	1.88	2.89	1.09
4L	3L-4	3,050	12,200	25,000	1800	303	4.29	6.08	0.73
4H	3H-4	6,100	24,400	25,000	1800	306	4.36	6.08	0.73
5L	4L-3	6,540	26,150	48,880	1800	537②	14.0	7.91	0.79
5H	4H-3	13,075	52,300	48,880	1800	541②	14.2	7.91	0.79
6	4H-4	47,400	94,800	72,400					
7	5-3	78,750	157,500	116,600					
8	5-3	120,000	240,000	200,000					

Designed to customer specification. Consult Rexnord.

- ① Max angular misalignment 1/2° per flexing pack sizes 1 to 3, 1/3° per flexing pack for unit sizes 4 and 5.
- ② Consult Rexnord if limit switch plate is required at speeds above 1,400 rpm.
- ③ Mass and inertia values calculated for units with solid hubs, minimum DBSE and without limit switch plate.
- ④ Coupling size specified per customer specification. Consult Rexnord.

Size	S1 (max)	S2 (max)	S2 Pilot	DBSE ②	D1	D2	E	F	J	K	L②	M	N	P	R	T1	V1	V2	W1	W2	X
	mm	mm	mm	mm	mm	mm	mm	mm	mm	mm	mm	mm	mm	mm	mm	mm	mm	mm	mm	mm	mm
1L	80	98	25.4	179.3	212	288	115	85.5	32.6	72	349.3	134	80	90	205	159.9	50.4	70.8	76.4	92.2	3.7
1H	80	98	25.4	179.3	212	288	115	85.5	22.6	72	349.3	134	80	90	205	159.9	60.4	80.8	86.4	103	3.7
2L	100	123	50.0	215.0	277	353	150	113	43.1	89	425.1	169	100	110	257	196.3	51.1	80.4	84.9	110	5.0
2H	100	123	50.0	215.0	277	353	150	113	29.1	89	425.1	169	100	110	257	196.3	65.1	94.4	98.9	124	5.0
3L	120	160	50.8	252.0	329	405	180	139	63.0	104	502.0	218	120	130	325	227.3	51.1	80.4	84.9	110	5.0
3H	120	160	50.8	252.0	329	405	180	139	49.0	104	502.0	218	120	130	325	227.3	65.1	94.4	98.9	124	5.0
4L	150	144①	25.0	304.1	409	485	230	166	70.0	100	584.1	201	150	130	310	308.1	76.0	109.4	125	131	6.0
4H	150	144①	25.0	304.1	409	485	230	166	46.0	100	584.1	201	150	130	310	308.1	100.0	133.4	250	155	6.0
5L	180	188	35.0	355.6	550	626	280	221	57.1	146	710.6	263	180	175	393	364.2	118.9	152.3	186	192	8.0
5H	180	188	35.0	355.6	550	626	280	221	25.1	146	710.6	263	180	175	393	364.2	150.9	184.3	218	224	8.0
6	230	223																			8.0
7	250	258																			12.0
8	300	305																			12.0

Designed to customer specification. Consult Rexnord.

- ① Larger bore available, consult Rexnord.
- ② Values for minimum DBSE shown, longer spacers available upon request.

Type 4 and Type 5

Type 4 Model designed to accept standard full flex AGMA gear couplings.

Type 5 Model designed to accept standard double engagement half flex AGMA gear couplings.

Type 4

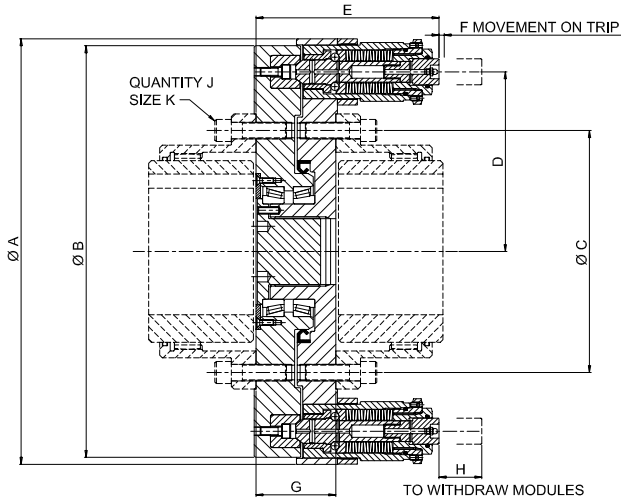

Type 5

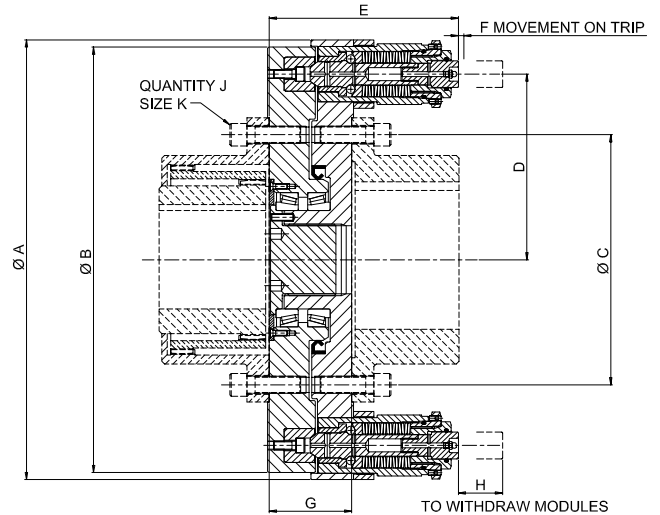

Size	Modules (Size-Qty)	Torque		Max speed Type 4 ① rpm	Max speed Type 5 ① rpm	Mass ② kg	Mass Moment of Inertia MR ² ② kgm ²
		Min Nm	Max Nm				
2.5	2H-4	2,800	7,470	1900	3000	55	0.62
3.0	2H-4	3,000	12,000	1700	2700	63	0.82
3.5	2H-6	5,100	18,500	1500	2400	84	1.97
4.0	3H-4	7,400	29,400	1200	2000	153	4.21
4.5	3H-6	11,800	42,000	1200	1800	177	5.57
5.0	3H-8	17,300	56,600	1200	1800	218	8.06
5.5	4H-4	21,300	74,000	1000	1500	359	17.98
6.0	4H-6	33,800	90,000	900	1400	411	23.01
7.0	4H-6	37,900	135,000	900	1300	494	33.57
8.0 to 11.0	↓	↓	↓	Designed to customer specification. Consult Rexnord.			
12.0	5-10	375,000	750,000				

① Balancing may allow up to 50 percent increase in speeds shown. Please consult Rexnord.

② Mass and moment of inertia values excluding gear coupling.

Size	AGMA Gear Coupling Size ①	A	B	C	D	E	F	G	H	J	K
		mm	mm	mm	mm	mm	mm	mm	mm	mm	in
2.5	2.5	318	306	181.0	133.5	165	5	106	34	6	5/8
3.0	3.0	345	333	206.4	147.0	165	5	106	34	8	5/8
3.5	3.5	385	373	241.3	166.9	165	5	112	34	8	3/4
4.0	4.0	476	461	279.4	200.0	208	6	112	50	8	3/4
4.5	4.5	504	488	304.8	214.0	214	6	117	50	10	3/4
5.0	5.0	546	530	342.9	234.9	217	6	133	50	8	7/8
5.5	5.5	648	612	368.3	269.7	292	8	147	68	14	7/8
6.0	6.0	678	643	400.1	285.1	292	8	163.5	68	14	7/8
7.0	7.0	748	712	463.6	320.0	292	8	163.5	68	16	1.00
8.0 to 11.0	8.0 to 11.0	Designed to customer specification. Consult Rexnord.									
12.0	12.0										

① The 820 Type 4 and Type 5 Torque Limiters can be supplied with or without the gear coupling. Please advise at time of order.

Type 6

Type 6 Model to accept a cardan shaft flange.

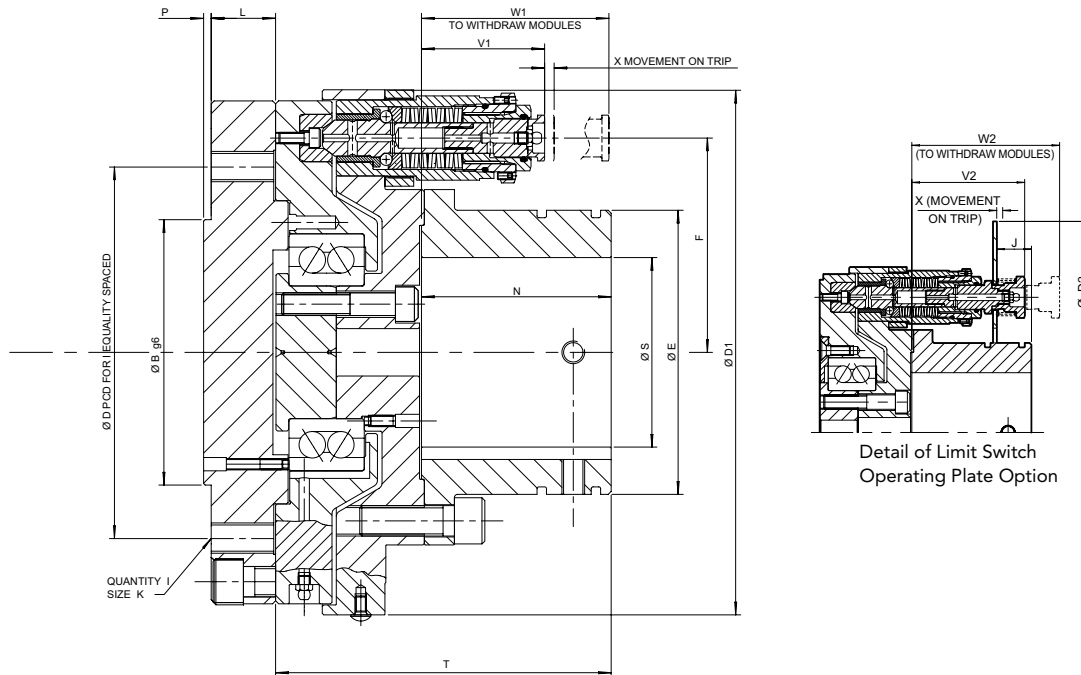

Size	Torque		Flange size mm	Max Speed rpm	Mass kg ^①	Max Angular Misalignment degrees	Max Axial Load kN	Max radial load N	Mass Moment of Inertia kgm ² ^①
	Min Nm	Max Nm							
2H	1,725	6,900	180	1800	60.9	5	28	200	0.5
			225	1800	60.9	5	28	200	0.5
3H	2,825	11,300	225	1800	99.5	5	40	620	1.16
			285	1800	99.5	5	40	620	1.16
4H	6,100	24,400	285	1800	201.5	5	58.5	1080	3.56
			315	1800	201.5	5	58.5	1080	3.56
5H	13,075	52,300	350	1800 ^②	323	5	96	2450	11.13
			390	1800 ^②	323	5	96	2450	11.13

① Mass and inertia values calculated for units with solid hubs and without limit switch plate

② 1800 rpm without the switch plate otherwise 1400rpm

Size	Flange size mm	B mm	D PCD mm	D1 mm	D2 mm	E mm	F mm	I mm	J mm	K mm	L mm	N mm	P mm	Max S mm	T mm	V1 mm	V2 mm	W1 mm	W2 mm	X mm
2H	180	110	155.5	277	353	150	113	8	29.1	M14	33	100	3	100	177	65.1	94.4	98.9	124	5
	225	140	196	277	353	150	113	8	29.1	M16	33	100	5	100	177	65.1	94.4	98.9	124	5
3H	225	140	196	329	405	180	139	8	49	M16	40	120	5	120	206	65.1	94.4	98.9	124	5
	285	175	245	329	405	180	139	8	49	M20	40	120	6	120	206	65.1	94.4	98.9	124	5
4H	285	175	245	409	485	230	166	8	46	M20	44	150	6	150	258	100	133.4	150	155	6
	315	175	280	409	485	230	166	8	46	M22	44	150	6	150	258	100	133.4	150	155	6
5H	350	220	310	550	626	280	221	10	25.1	M22	①	180	7	180	308	150.9	184.3	218	224	8
	390	250	345	550	626	280	221	10	25.1	M24	①	180	7	180	308	150.9	184.3	218	224	8

① No adaptor required

Autogard 820 Series Remote Reset

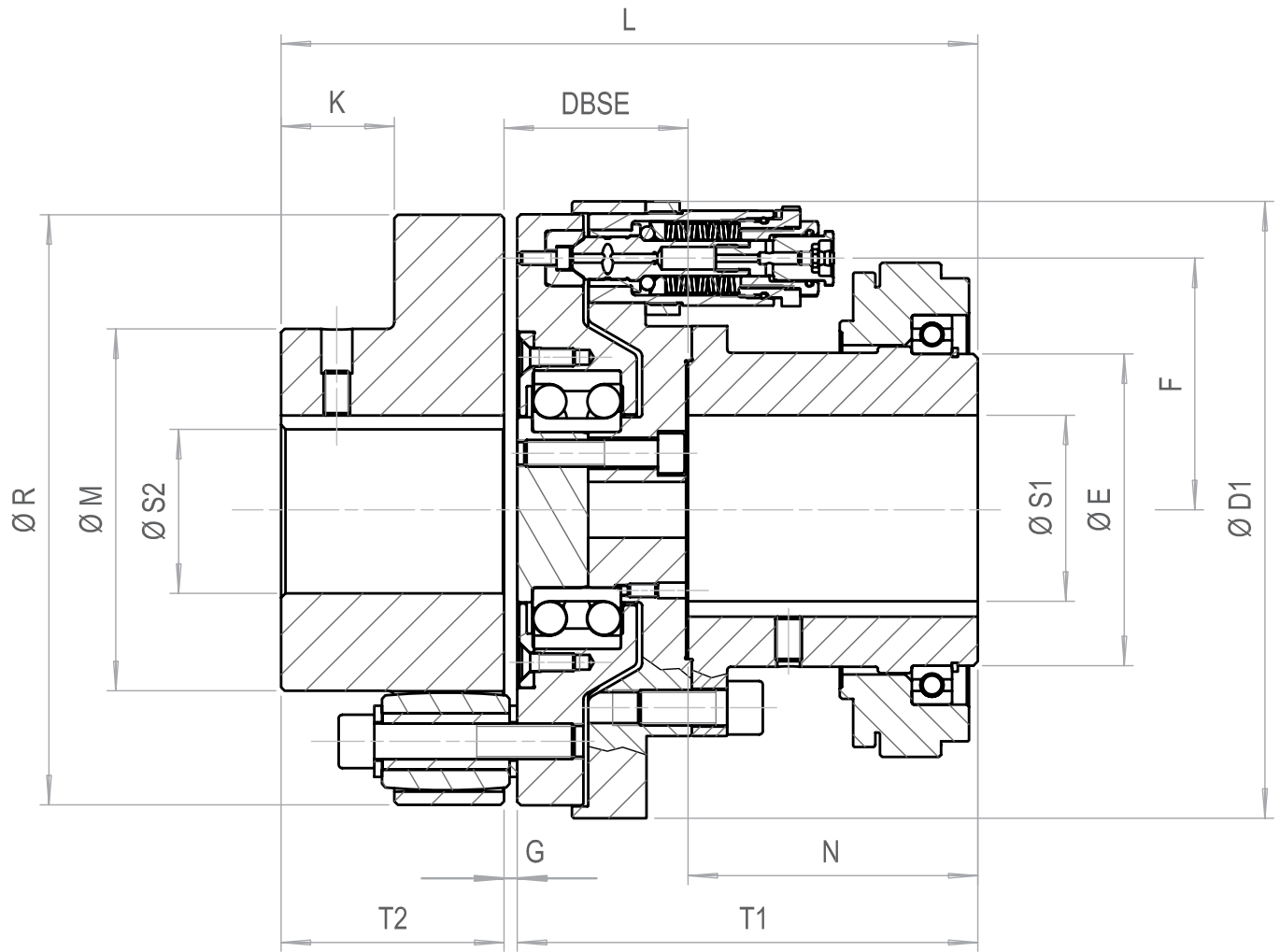

Size	Torque		Max. speed rpm	S1 (max) mm	S2 (max) mm	DBSE mm	D1 mm	E mm	F mm	G mm	K mm	L mm	M mm	N mm	R mm	T1 mm	T2 mm	Mass kg	Mass moment of Inertia MR ² kgm ³
	Min	Max																	
	Nm	Nm																	
820-2H	1,725	6,900	2,400	90	115	83.0	277.0	140.0	113.0	6.0	50.8	313.0	162.5	130.0	265.0	207.0	100.0	86	0.554
820-3H	2,825	11,300	2,150	110	130	93.4	329.0	170.0	139.0	7.0	60.0	359.0	188.5	146.0	314.0	232.0	120.0	146	1.29
820-4H	6,100	24,400	1,800	140	170	114.8	409.0	220.0	166.0	7.0	89.9	453.0	248.0	188.0	375.0	296.0	150.0	276	3.83

To control the reset of the Autogard a pneumatic supply with a pressure range of 0.4 to 0.8 MPa (60-120 Psi) is required.



Maintenance and General Safety Information

Maintenance

The frequency of maintenance will depend on the operating environment and number of trips, but once every three months should be adequate in most applications. The amount of maintenance required is dependent upon the operating conditions and should be maintained at least as frequently as the adjacent drive components. In adverse conditions, consult Rexnord.

General Safety

Autogard Torque Limiters are reliable units, built to high standards of workmanship. Similar to all mechanical devices, each application must be considered on its own merits with reference to safety (i.e., lifting equipment, explosive conditions, etc). As rotating components, adequate guarding must be provided, in accordance with local codes. The intended use of torque limiters is for the protection of industrial machinery and should not be regarded as human safety devices. Rexnord staff is always available to discuss particular applications.

Special Designs

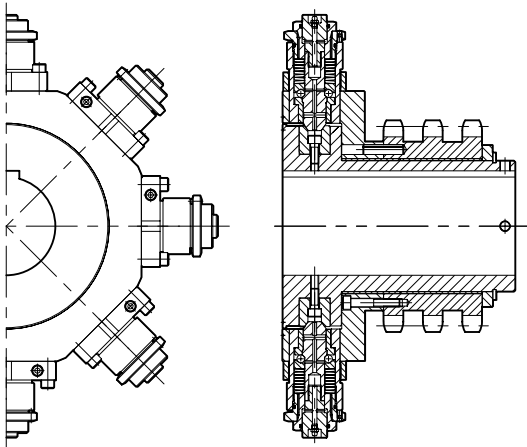

Radial Module with Triplex Sprocket

Designed for tight axial space constraints

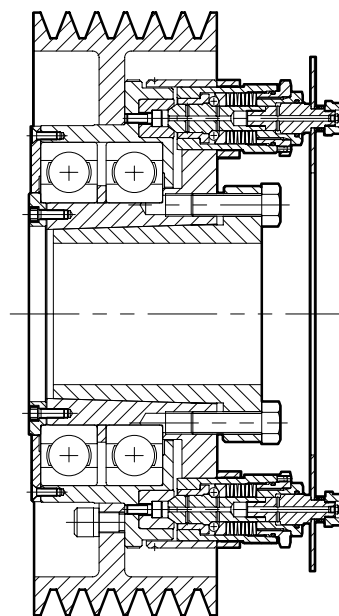

Standard 820 Series with pulley

Designed for v-belt pulley applications

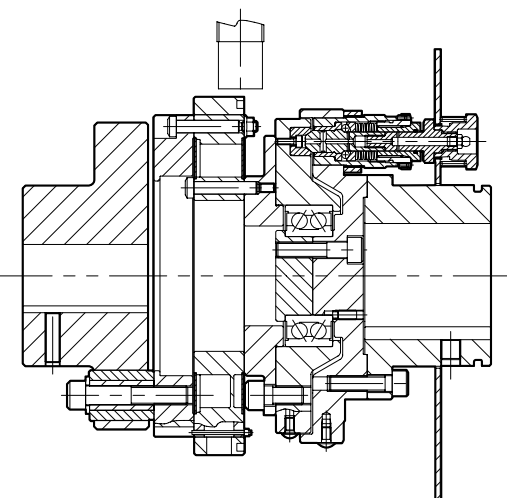

Standard 820 Series with Monitorq[®] Torque Monitoring Equipment

Designed for overload protection and condition monitoring



UK: +44 1285 640333
Germany: +49 2129 912 2960
Australia: +61 3 9736 6002

China: +86 021 52436100
India: +91 040 23078243
USA: 800-767-3539

autogard.uk@rexnord.com

www.rexnord.com

Why Choose Rexnord?

When it comes to providing highly engineered products that improve productivity and efficiency for industrial applications worldwide, Rexnord is the most reliable in the industry. Commitment to customer satisfaction and superior value extend across every business function.

Delivering Lowest Total Cost of Ownership

The highest quality products are designed to help prevent equipment downtime and increase productivity and dependable operation.

Valuable Expertise

An extensive product offering is accompanied by global sales specialists, customer service and maintenance support teams, available anytime.

Solutions to Enhance Ease of Doing Business

Commitment to operational excellence ensures the right products at the right place at the right time.

REXNORD

Rexnord Corporation

Rexnord is a growth-oriented, multi-platform industrial company with leading market shares and highly trusted brands that serve a diverse array of global end markets.

Process and Motion Control

The Rexnord Process and Motion Control platform designs, manufactures, markets and services specified, highly engineered mechanical components used within complex systems where our customers' reliability requirements and the cost of failure or downtime are extremely high.

Water Management

The Rexnord Water Management platform designs, procures, manufactures and markets products that provide and enhance water quality, safety, flow control and conservation.