

⚠ DANGER Indicates a hazard which, if not avoided, will result in serious injury or death.

⚠ WARNING Indicates a hazard which, if not avoided, could result in serious injury or death.

⚠ CAUTION Indicates a hazard which, if not avoided, could result in minor or moderate personal injury.

NOTICE Indicates information considered important, but not hazard-related (e.g. messages relating to property damage).

GENERAL SAFETY INSTRUCTIONS

⚠ WARNING

- Read and follow all instructions carefully.
- Disconnect and lock out power before installation and maintenance. Working on or near energized equipment can result in severe injury.
- Do not operate equipment without guards in place. Exposed equipment can result in severe injury or death.

- Read and understand the information in this section and in this manual completely before installing, operating or maintaining this equipment. Failure to follow this instruction could result in severe injury or death.

⚠ CAUTION

- Perform periodic inspections. Equipment may fail prematurely and could become unsafe if not properly inspected and maintained. Failure to follow this instruction could result in mild or moderate personal injury.

TYPE R10

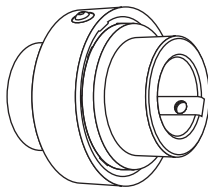

TYPE R35

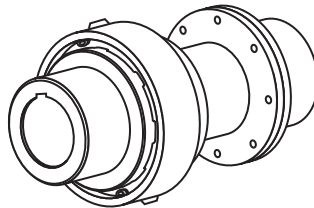

TYPE R31

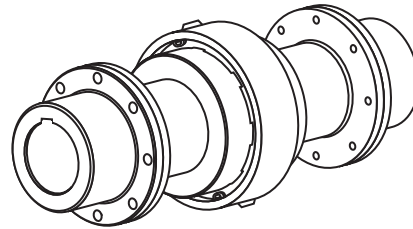

HOW TO USE THIS MANUAL

This manual provides detailed instructions on maintenance, installation, and parts identification. Use the table of contents below to locate required information.

TABLE OF CONTENTS	Page
Introduction.....	1
Close-Coupled, Spacer, or Blind Installation	1-4
Preventive Maintenance & Element Replacement	5
Parts Identification	6-8

CAREFULLY FOLLOW THE INSTRUCTIONS IN THIS MANUAL FOR OPTIMUM PERFORMANCE AND TROUBLE-FREE SERVICE.

INTRODUCTION

This manual applies to Falk sizes 5R thru 80R Wrapflex couplings in types R10, R31, and R35.

CAUTION: Consult applicable local and national safety codes for proper guarding of rotating members. Observe all safety rules when installing or servicing couplings.

WARNING: Lockout starting switch of prime mover and remove all external loads from drive before installing or servicing couplings.

WARNING: Operating temperature range is: -40°C (-40°F) to 95°C (200°F). Consult Regal Rexnord on any application where the operating temperature is

lower than 0°C (32°F) or greater than 65°C (150°F). Chemical and fluid exposure may also impact coupling performance. Consult Regal Rexnord for chemical and fluid compatibility or refer to [Manual 497-110](#).

INSTALLATION OF TYPE R WRAPFLEX COUPLINGS

Installation

Falk Wrapflex couplings require only standard mechanics tools for installation. Specifically, hex keys or hex head sockets, torque wrench, straight edge, and feeler gauges or dial indicator are required. Coupling sizes 5R thru 50R are generally furnished for clearance fit with two setscrews, one over keyway and one at 90 degrees from the keyway. Coupling sizes 60R thru 80R are furnished for interference fit with keyway and one setscrew as standard.

1. Mounting Hubs

Lock out starting switch of prime mover. Clean all metal parts using a nonflammable solvent. Check hubs, shafts and keyways for burrs. Deburr, if necessary.

IMPORTANT: Prior to mounting an R10 hub, place the cover on one shaft on which the R10 hub will be mounted.

CLEARANCE FIT HUBS — Do not heat clearance fit hubs. Install keys. Mount hubs with the hub flange face (R10 hubs) or hub register face (R31/R35 shaft hubs) flush with the shaft end, or as otherwise specified. Tighten the hub

R10 Hubs

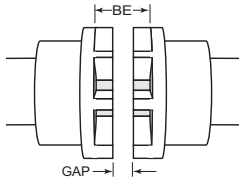

R31/R35 Shaft Hubs (R31)

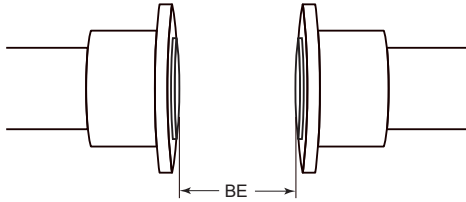

R31/R35 Shaft Hub & R10 Hub (r35)

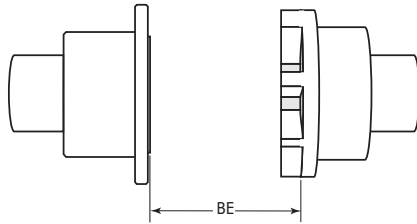

setscrew(s) to the specified torque (See Table 1). Position drives for approximate hub gap (R10 hubs — See Table 4 on Page 5) or distance between shaft ends (R31 or R35 spacer coupling) with minimum angular and offset alignment.

INTERFERENCE FIT HUBS — Heat hubs to a maximum of 135°C (275°F) using an oven, torch, induction heater or oil bath.

When an oxy-acetylene or blow torch is used, use an excess acetylene mixture. Mark hubs near the center of their length in several places on hub body with a temperature sensitive crayon, 135°C (275°F) melt temperature. Direct flame towards hub bore using constant motion to avoid overheating an area.

WARNING: If an oil bath is used, the oil must have a flash point of 177°C (350°F) or higher. Do not rest hubs on the bottom of the container. Do not use an open flame in a combustible atmosphere or near combustible materials.

Heat hubs as instructed above. Mount hubs as quickly as possible with the hub flange face (R10 hubs) or hub register face (R31/R35 shaft hubs) flush with the shaft end, or as otherwise specified. Allow hubs to cool before proceeding. Insert setscrew(s), if required, and tighten to specified torque (see Table 1). Position drives for approximate hub gap (R10 hubs – see Table 4) or distance between shaft ends (R31 or R35 spacer coupling) with minimum angular and offset alignment.

2. Install Spacer Hub(s) (R31/R35 only)

Spacer Hub Installation

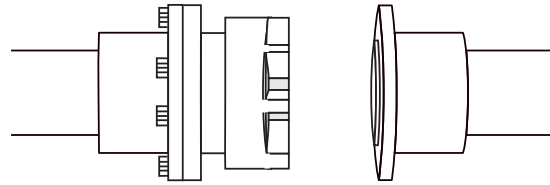

Carefully position spacer hub(s) on register of shaft hub and fasten parts together. Torque flange fasteners to specification in Table 1.

TABLE 1 — Wrapflex™ Fasteners & Tightening Torques

COUPLING SIZE	R10 Hub Setscrew †				Cover Fasteners ‡					
	Screw Size	Hex Head Key Size	Tightening Torque		Screw Size	Hex Head Key Size	Tightening Torque			
			(N-m)	(lb-in)			Nylon Cover		Steel Cover	
							(N-m)	(lb-in)	(N-m)	(lb-in)
5R	M8	M4	12	110	M4	M2.5	1.0	10	1.0	10
10R	M10	M5	25	220	M4	M2.5	1.0	10	1.0	10
20R	M10	M5	25	220	M6	M4	5.0	45	5.0	45
30R	M12	M6	50	440	M6	M4	5.0	45	5.0	45
40R	M12	M6	50	440	M8	M5	10.0	90	10.0	90
50R	M16	M8	100	880	M8	M5	10.0	90	10.0	90
60R	M16	M8	100	880	M10	M6	15.0	135
70R	M16	M8	100	880	M10	M6	15.0	135
80R	M16	M8	100	880	M10	M6	15.0	135

TABLE 1 — Wrapflex Fasteners & Tightening Torques (Cont.)

COUPLING SIZE	Shaft Hub Size	R31/R35 Shaft Hub Setscrew *				R31/R35 Flange Fasteners					
		Screw Size	Hex Head Key Size	Tightening Torque		Screw Size	Screw Length	Qty. per Flange	Part No. Flange Set	Tightening Torque	
				(lb-in)	(N-m)					(N-m)	(lb-in)
5R	1020T	1/4"	1/8"	70	8.0	M6	16 mm	4	3700046	15	130
10R	1030T	1/4"	1/8"	70	8.0	M6	16 mm	8	3700047	15	130
20R	1040T	3/8"	3/16"	240	27	M6	16 mm	8	3700047	15	130
30R	1050T	3/8"	3/16"	240	27	M8	20 mm	8	3700048	35	310
40R	1060T	3/8"	3/16"	240	27	M10	25 mm	8	3700049	68	600
40R	1070T	3/8"	3/16"	240	27	M10	25 mm	12	3700050	68	600
50R	1080T	3/8"	3/16"	240	27	M12	30 mm	12	3700051	125	1100
60R	1090T	3/8"	3/16"	240	27	M16	40 mm	12	3700237	200	1800
70R	1100T	1/2"	1/4"	600	68	M20	45 mm	12	3700238	400	3600
70R	1110T	1/2"	1/4"	600	68	M20	45 mm	12	3700238	400	3600
80R	1120T	5/8"	5/16"	1200	135	M24	50 mm	12	3700436	700	6200
80R	1130T	5/8"	5/16"	1200	135	M27	60 mm	12	3700437	1000	8800

† For R10 hub sizes 5R to 50R, clearance fits with single keyway and two setscrews (one over keyway, one at 90 degrees) are standard. For R10 hub sizes 60R to 80R, interference fits with single keyway and one setscrew are standard. Clearance fits for sizes 60R to 80R are custom and will include two setscrews.

‡ Do not exceed tightening torque values listed in Table 1. For nylon covers, tighten fasteners until "snug tight" only. For steel covers, tighten fasteners until snug tight plus 1/8 turn.

● For R31/R35 shaft hub sizes 5R to 50R, clearance fits with single keyway and 1 setscrew is standard. For R31/R35 shaft hub sizes 60R to 80R, interference fits with single keyway and one setscrew are standard. Clearance fits for sizes 60R to 80R are custom.

ALIGNMENT — MAXIMIZING PERFORMANCE & LIFE

The performance and life of the coupling depends largely upon how it is installed and maintained. Before installing the coupling, check for soft foot and make certain that foundations of equipment to be connected meet manufacturer's requirements. The use of stainless steel shims is recommended.

Alignment is shown using spacer bar and straight edge. This practice has proven to be adequate for many industrial applications. However, for superior final alignment, the use of dial indicators, laser alignment systems or graphical analysis is recommended. Measuring misalignment and positioning equipment within alignment tolerances is simplified with an alignment computer. These calculations can also be done graphically or mathematically.

Falk's type R10, R31, and R35 Wrapflex™ couplings are not appropriate for limited end-float applications.

3. Gap & Angular Alignment

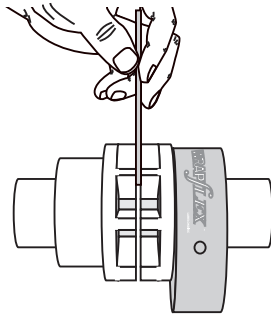

Use a spacer bar equal in thickness to the gap specified in Table 4. Insert bar between hub teeth, as shown, to same depth at 90° intervals and measure clearance between bar and hub tooth face with feelers. The difference in minimum and maximum gap measurements must not exceed the ANGULAR installation limits specified in Table 4.

If a dial indicator is used, place it on one hub or shaft and take readings from the tooth gap face or other parallel face of the second hub. Both hubs MUST be rotated together to obtain accurate readings in this manner.

4. Offset Alignment

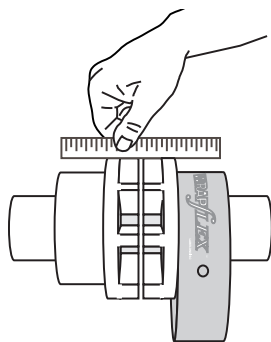

Align so that a straight edge rests squarely (or within the limits specified in Table 4) on both hubs as shown at 90° intervals. Check with feelers. The clearance must not exceed the PARALLEL offset installation limits specified in Table 4.

If a dial indicator is used, place it on one hub and rotate that hub through 360° while taking readings from the flange outside diameter of the other hub. Best results are achieved by rotating both hubs together. Total indicator reading (TIR) must not exceed two times the installation limit specified in Table 4.

Tighten all foundation bolts and repeat the parallel offset, gap, and angular alignment checks. Realign the coupling, if necessary.

5. Combined Angular & Offset Alignment

The amount of angular misalignment will limit parallel offset misalignment capacity, and vice-versa. Refer to the "Combined Misalignment Limits" graph on Page 5.

6. Element Installation

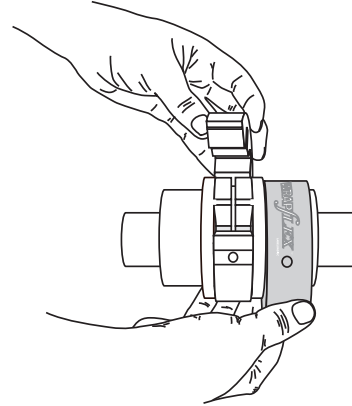

Rotate one hub so that the teeth of both hubs are aligned axially. Spread apart the element so that it will fit over the hub teeth and "wrap" the element between the two hubs.

7. Cover Installation

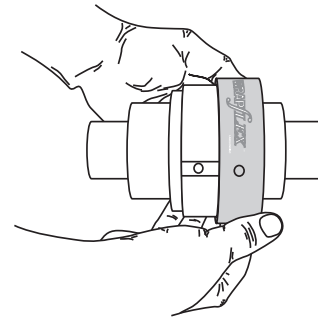

Move the cover alongside the element with the fastener hole of the cover approximately aligned with the locating slot on the element. A soft mallet may be needed to install the cover on larger size couplings.

If using a nylon cover, the cover's locating key will engage the slot in the element when cover and element are properly aligned — this will aid in blind assembly. Push or tap the cover onto the element until it is centered axially on the element.

If using a steel cover, push or tap the cover onto the element and center the cover axially while making sure that the fastener holes on the cover and element are aligned. For the 5R-50R steel covers, use the flats on the O. D. of the steel cover as a visual aid to align the cover's threaded hole with the slot and clearance hole of the element.

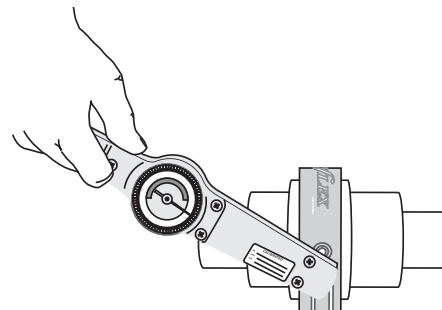

Install and tighten cover fasteners. DO NOT exceed tightening torque values specified in Table 1. For nylon covers, install fasteners until “snug tight” only. For steel covers, install fasteners until “snug tight” plus 1/8 turn.

CAUTION: Do not operate the coupling without the cover fasteners installed.

8. Removal of R31/R35 Spacer Hub

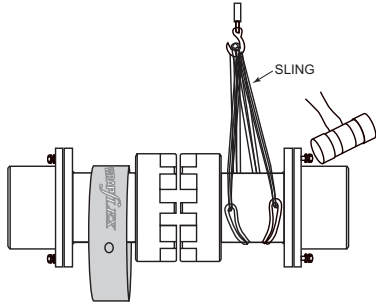

Remove cover fasteners and slide cover off element to one side. Remove element. Remove all but two flange fasteners, opposite each other, on each shaft hub. While supporting one spacer hub (with slings or other device), loosen the remaining two fasteners about 6 mm (1/4-inch), no more. Tap the fasteners with a mallet to disengage the Wrapflex™ spacer hub from the shaft hub. Remove the final two fasteners, while still supporting the spacer hub, and lift out the spacer hub. Repeat for second spacer hub.

CAUTION: Spacer hub must be supported while removing flange fasteners to prevent it from falling.

9. Installation Instructions For Hub With QD Bushing

For mounting of QD bushing and Falk™ type R hub, refer to manufacturer’s installation instructions supplied with the QD Bushing.

Use factory supplied hardware (hex head cap screws and lock washers) only for mounting the QD bushing in the Falk type R coupling hub. DO NOT use the hardware supplied with the QD Bushing.

TABLE 2 — Type R10 Recommended Tightening Torque for QD Bushings (Inch Fasteners)

Coupling Size	QD Bushing	Hex Head Cap Screw	Tightening Torque	
			lb-in	Nm
5R	JA	#10-24UNC x 1.00	60	7
10R	JA	#10-24UNC x 1.00	60	7
20R	SD	.250-20UNC x 1.00	108	12
30R	SD	.250-20UNC x 1.00	108	12
40R	SF	.375-16UNC x 1.25	360	41
50R	E	.500-13UNC x 1.75	720	81
60R	J	.625-11UNC x 2.50	1620	183
70R	J	.625-11UNC x 2.50	1620	183
80R	M	.750-10UNC x 3.00	2700	305

★ Fasteners are SAE Grade 5.

TABLE 2 — Type R10 Recommended Tightening Torque for QD Bushings (Metric Fasteners)

Coupling Size	QD Bushing	Hex Head Cap Screw	Tightening Torque	
			Nm	lb-in
5R	JA	M5 x 0,8 x 25mm	7	60
10R	JA	M5 x 0,8 x 25mm	7	60
20R	SD	M6 x 1,0 x 25mm	12	108
30R	SD	M6 x 1,0 x 25mm	12	108
40R	SF	M10 x 1,5 x 35mm	41	360
50R	E	M12 x 1,75 x 45mm	81	720
60R			Refer to the Factory	
70R				
80R				

† Fasteners are ISO 8,8 DIN 933. Washers are DIN 1278.

10. Blind Assembly

The term blind assembly refers to the ability to complete the assembly or connection of the coupling components without being able to actually see the coupling.

Wrapflex couplings may be blind or axially assembled within motor adapters or bell housings.

INSTRUCTIONS

1. Mount both hubs on their respective shafts with the shaft ends flush with the end of the hub faces, unless instructed otherwise. Double-check the spacing of the assembly to be sure the required coupling hub face gap will be achieved when assembled.

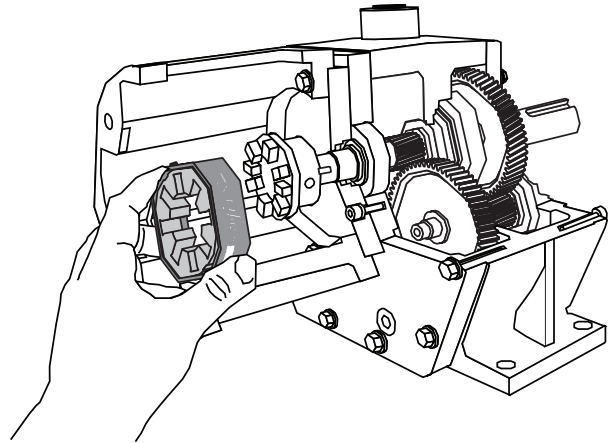

2. Mount the cover onto the flexible element, making certain to tighten both cover fasteners. Make certain the element split is not overlapping, and position the assembled cover/element assembly onto the lower of the two hubs if a vertical assembly, or on the hub within the bell housing or motor adapter for horizontal arrangements.

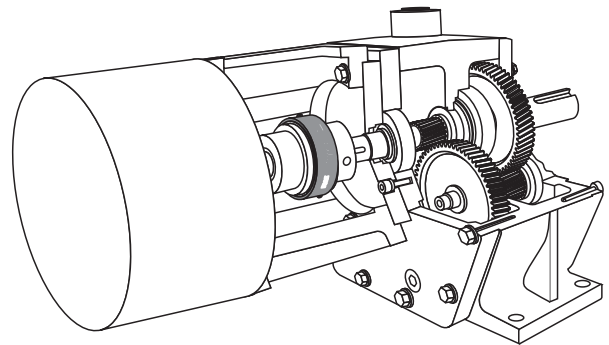

3. Bring the motor shaft hub axially into engagement with the element until the teeth seat within the element and the motor or bell housing adapter pilot is properly seated. Wrapflex hubs have a slightly tapered lead to facilitate this engagement. Complete the assembly by torquing the motor to the bell housing or motor adapter with the proper fasteners.

11. Preventive Maintenance & Element Replacement

A periodic visual inspection of the element should be performed with the equipment shut down and locked out. Without removing the cover, check for element wear debris or cracks in the side of the element just underneath the cover. If wear debris or cracks are noted, the following maintenance procedure should be performed.

1. Remove the cover and element and inspect the element for wear. Replace the element if wear exceeds 10% of the tooth thickness or cracks have appeared with one of the following characteristics:
 - a. One or more cracks have broken through to the O.D. of the element, such that splitting or separation of the element web is imminent.
 - b. One or more cracks extend the full thickness of a tooth.

2. Check the alignment before re-installing or replacing the element. Excessive or rapid element wear is generally an indication of coupling misalignment. If alignment is not within the installation limits specified in Table 4, re-align the coupling according to the alignment instructions.

3. Check the tightening torque of all fasteners.

If it is not possible to perform a periodic visual inspection, the user should consider removing and inspecting the element on an annual basis or other schedule, depending on the need to avoid unscheduled breakdowns or work stoppages.

PARALLEL MISALIGNMENT

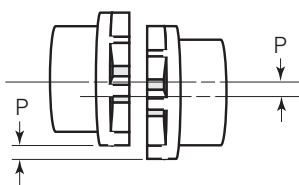

ANGULAR MISALIGNMENT

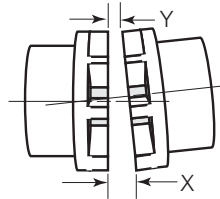

NORMAL GAP

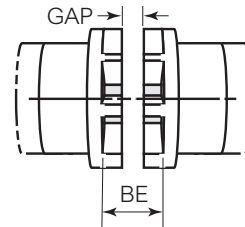
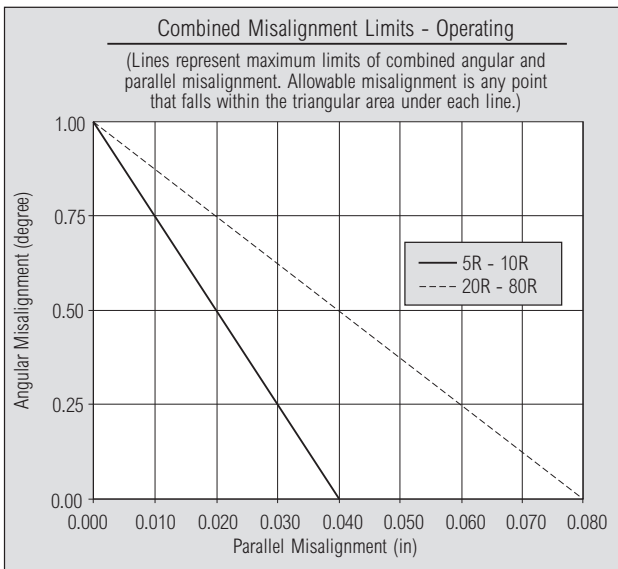

TABLE 4 — Alignment, Installation, & Operating Limits ★

SIZE	Distance Between Shaft Ends (BE) ■		Installation limits								Operating Limits						Allow Speed (rpm)
			Parallel Offset - P		Angular (X - Y)			Normal Gap ± 10% ■		Parallel Offset - P		Angular (X - Y)			Normal Gap ± 10% ■		
	mm	Inch	Max mm	Max Inch	Max Degrees	Max mm	Max Inch	mm	Inch	Max mm	Max Inch	Max Degrees	Max mm	Max Inch	mm	Inch	
5R	20,0	.78	0,50	.020	.25	0,28	.011	2,00	.078	1,00	.040	1,00	1,12	.044	2,00	.078	4500
10R	24,0	.94	0,50	.020	.25	0,33	.013	2,00	.078	1,00	.040	1,00	1,32	.052	2,00	.078	4500
20R	32,0	1.26	1,00	.040	.25	0,44	.018	2,00	.078	2,00	.080	1,00	1,78	.070	2,00	.078	4500
30R	36,0	1.42	1,00	.040	.25	0,51	.020	2,00	.078	2,00	.080	1,00	2,06	.081	2,00	.078	4500
40R	47,0	1.85	1,00	.040	.25	0,65	.026	5,00	.188	2,00	.080	1,00	2,62	.103	5,00	.188	3600
50R	61,0	2.39	1,00	.040	.25	0,83	.033	5,00	.188	2,00	.080	1,00	3,32	.131	5,00	.188	3000
60R	75,4	2.97	1,00	.040	.25	0,99	.039	5,00	.188	2,00	.080	1,00	3,98	.157	5,00	.188	2500
70R	84,4	3.31	1,00	.040	.25	1,18	.046	5,00	.188	2,00	.080	1,00	4,71	.186	5,00	.188	2100
80R	96,8	3.82	1,00	.040	.25	1,43	.056	6,00	.250	2,00	.080	1,00	5,73	.225	6,00	.250	1800

★ Angular misalignment is dimension "X" minus "Y". Parallel misalignment is distance "P" between the hub center lines.

■ "BE" dimension tolerance is ± 10% of "Normal Gap" listed. Hubs can be mounted for shorter than standard BE lengths, as long as shaft ends do not extend into "Gap" and keys do not extend beyond barrel of hub into tooth space. Stake key(s) in place for an interference fit without setscrew. Overhanging hubs is not recommended.



PARTS IDENTIFICATION

All coupling parts have identifying part numbers as shown below.

PART NUMBER LOCATION

TYPE R31

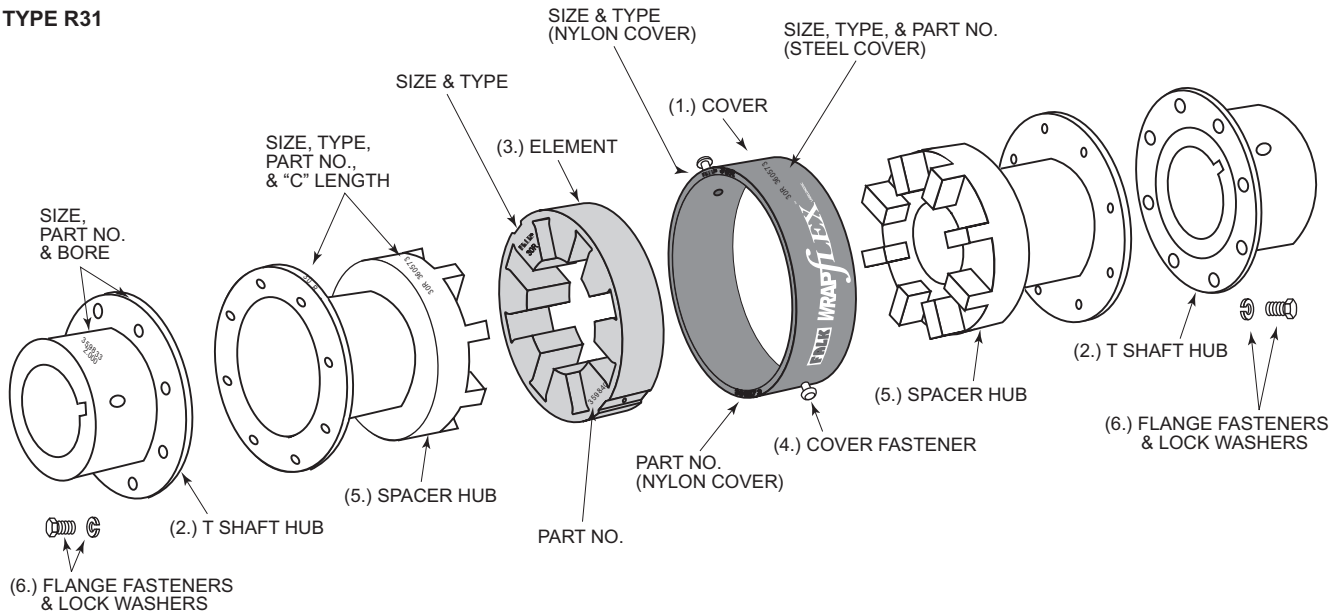

ORDER INFORMATION

1. Identify part(s) required by name above.
2. Furnish the following information.

EXAMPLE:

Coupling Size: 30

Coupling Type: R31

Model:

Cover Type:

Nylon (Std.)

Steel/Epoxy

Bore: 2.000

Keyway: .500 x .250

Distance between Shaft Ends (BE): 7.250

Spacer Hub "C" Length: 2.9663

(Specify two "C" length values if spacer hubs are not equal length)

3. Visit regalrexnord.com for Wrapflex replacement parts.

PART DESCRIPTION

1. Cover
2. Shaft Hubs (2) – Specify bore and keyway
3. Element
4. Cover Fasteners (2) — Supplied with element
5. Spacer Hubs (2) – Specify BE & "C" length
6. Flange Fasteners & Lock Washers

PARTS IDENTIFICATION

All coupling parts have identifying part numbers as shown below.

PART NUMBER LOCATION

TYPE R35

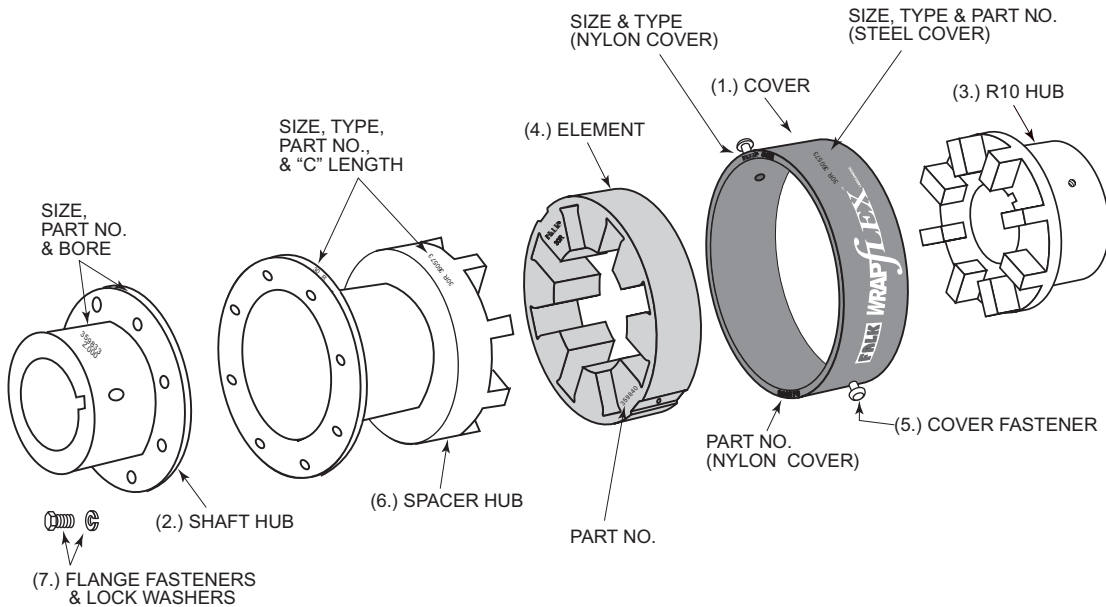

ORDER INFORMATION

1. Identify part(s) required by name above.
2. Furnish the following information.

EXAMPLE:

Coupling Size: 30

Coupling Type: R35

Model:

Cover Type:

Nylon (Std.)

Steel/Epoxy

Bore: 2.000

Keyway: .500 x .250

Distance between Shaft Ends (BE): 5.000

Spacer Hub "C" Length: 3.6327

3. Visit [regalrexnord.com](https://www.regalrexnord.com) for Wrapflex replacement parts.

PART DESCRIPTION

1. Cover
2. Shaft Hub (1) – Specify bore & keyway
3. R10 Hub (1) – Specify bore and keyway
4. Element
5. Cover Fasteners (2) — Supplied with Element
6. Spacer Hub (1) – Specify BE & "C" Length
7. Flange Fasteners & Lock Washers

FALK™

The proper selection and application of products and components, including assuring that the product is safe for its intended use, are the responsibility of the customer. To view our Application Considerations, please visit <https://www.regalrexnord.com/Application-Considerations>.

To view our Standard Terms and Conditions of Sale, please visit <https://www.regalrexnord.com/Terms-and-Conditions-of-Sale>.

"Regal Rexnord" is not indicative of legal entity. Refer to product purchase documentation for the applicable legal entity. Regal Rexnord, Falk, and Wrapflex are trademarks of Regal Rexnord Corporation or one of its affiliated companies.

© 2009, 2026 Regal Rexnord Corporation, All Rights Reserved. MCM-498-110-FK-EN-US 06/26

RegalRexnord™